

240W AC-to-48VDC Industrial Power Supply

Data Sheet | SD.PE-0026-MW



SD.PE-0026-MW is a compact, high-performance AC/DC industrial power supply designed for reliable operation in demanding environments. It supports an ultra-wide AC input range of 85 ~ 264 VAC and delivers a stable 48 VDC output, providing up to 240 W of power for industrial appliances such as MIS series PoE switches and M360-X/VX200 CPE/AP models. With efficiency of up to 95.5% and ultra-low standby power consumption of down to 1.2 W, the SD.PE-0026-MW significantly improves energy efficiency while supporting carbon-reduction initiatives.

Designed for easy installation, the unit supports DIN-rail mounting on TS-35/7.5 and TS-35/15 rails. The unit's body is 40 mm wide, allowing for space-saving in cabinets.

Built for extended service life, the SD.PE-0026-MW operates reliably over a wide temperature range from -40°C to +70°C (up to +50°C at full load) and incorporates comprehensive protection features, including short-circuit, overload, over-voltage, and over-temperature protection, to ensure safe and dependable power delivery for industrial applications.



Key Features and Benefits

- Ultra-wide AC input range: 85 ~ 264 VAC
- 40 mm slim design
- Protections: short circuit, overload, over voltage and over temperature
- Fanless design, cooling by free air convection
- -40 ~ +70°C wide range operation temperature (> +50°C derating)
- High efficiency up to 95.5% and ultra-low power dissipation in idle state (down to 1.2 W)
- Built-in DC OK relay contact
- DIN rail TS-35/7.5 or 15 installation

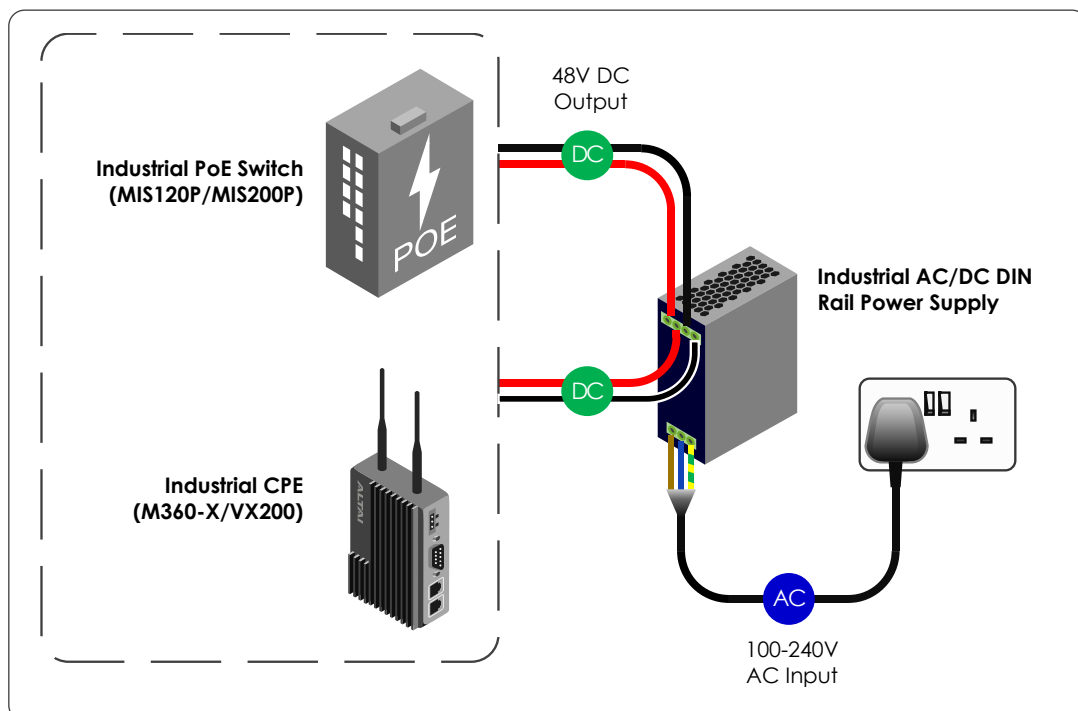

240W AC-to-48VDC Industrial Power Supply

Data Sheet | SD.PE-0026-MW



OUTPUT	DC VOLTAGE	48 V
	RATED CURRENT	5 A
	CURRENT RANGE	0 ~ 5 A
	RATED POWER	240 W
	RIPPLE & NOISE (max.) ^{Note 2}	150 mVp-p
	VOLTAGE ADJ. RANGE	48 ~ 55 V
	VOLTAGE TOLERANCE ^{Note 3}	±1.0%
	LINE REGULATION	±0.5%
	LOAD REGULATION	±1.0%
	SETUP, RISE TIME	1200 ms, 60 ms/230 VAC; 2500 ms, 150 ms/115 VAC at full load
	HOLD UP TIME (Typ.)	20 ms/230 VAC; 20 ms/115 VAC at full load
INPUT	AC VOLTAGE RANGE	85 ~ 264 VAC
	DC VOLTAGE RANGE	120 ~ 370 VDC
	NO LOAD POWER CONSUMPTION (Typ.)	1.2 W @ 115 VAC & 230 VAC
	FREQUENCY RANGE	47 ~ 63 Hz
	POWER FACTOR (Typ.)	PF > 0.95/230 VAC; PF > 0.98/115 VAC at full load
	EFFICIENCY (Typ.)	95.5%
	AC CURRENT (Typ.)	2.6 A/115 VAC; 1.3 A/230 VAC
	INRUSH CURRENT (Typ.)	Cold start 15 A/115 VAC; 30 A/230 VAC
	LEAKAGE CURRENT	< 1 mA/240 VAC
PROTECTION	OVERLOAD	105 ~ 130% rated output power Hiccup mode when output voltage < 30%, recovers automatically after fault condition is removed Protection type: Constant current limiting without shutdown within 30% ~ 100% rated output voltage, recovers automatically after fault condition is removed
	OVER VOLTAGE	Max. 63V Protection type: Hiccup mode, recovers automatically after fault condition is removed
	OVER TEMPERATURE	Protection type: Shut down o/p voltage, recovers automatically after temperature goes down
FUNCTION	DC OK RELAY CONTACT	Relay Contact Ratings (Max.): 30 VDC/1 A, 30 VAC/0.5A resistive load
ENVIRONMENT	WORKING TEMP.	-40 ~ +70°C (Refer to "Derating Curve")
	WORKING HUMIDITY	20 ~ 95% RH non-condensing
	STORAGE TEMP., HUMIDITY	-40 ~ +85°C, 10 ~ 95% RH non-condensing
	TEMP. COEFFICIENT	±0.03%/°C (0 ~ 50°C)
	VIBRATION	Component: 10 ~ 500 Hz, 2G 10 min./1 cycle, 60 min. each along X, Y, Z axes; Mounting: Compliance to IEC60068-2-6
SAFETY & EMC ^{Note 6}	SAFETY STANDARDS	UL/CUL 61010-1/-2-201; TUV BS EN/EN62368-1, BS EN IEC/EN IEC 61558-1/-2-16, BS EN/EN61010-1/-2-201; CB IEC 62368-1, IEC 61558-1/-2-16, IEC 61010-1-2-201; RCM AS/NZS 62368-1, AS/NZS 61558-1/-2-16; BSMI CNS 15598-1; CCC GB4943.1; EAC TP TC 004 approved
	OVER VOLTAGE CATEGORY ^{Note 4}	IEC/EN 61558-1/-2-16 (OVC III, Altitude up to 2000 m) IEC/EN/UL 61010 (OVC II, Altitude up to 5000 m) IEC/EN 62368-1 (OVC II, Altitude up to 5000 m)
	SAFETY EXTRA-LOW VOLTAGE (SELV)	IEC/EN 61558-2-16 (SELV) IEC/EN/UL 61010-2-201 (SELV)

		IEC/EN 62368-1 (SELV/ES1)		
	WITHSTAND VOLTAGE	I/P-O/P: 4k VAC; I/P-FG: 2k VAC; O/P-FG: 1.5k VAC; O/P-DC OK: 0.5k VAC		
	ISOLATION RESISTANCE	I/P-O/P, I/P-FG, O/P-FG: 100M Ohms / 500 VDC / 25°C / 70% RH		
	EMC EMISSION	Parameter	Standard	Test Level/Note
		Conducted	BS EN/EN55032 (CISPR32), BS EN/EN61204-3, CNS 15936	Class B
		Radiated	BS EN/EN55032 (CISPR32), BS EN/EN61204-3, CNS 15936	Class B
		Harmonic Current	BS EN/EN61000-3-2	Class A
		Voltage Flicker	BS EN/EN61000-3-3	---
	EMC IMMUNITY	BS EN/EN55035, BS EN/EN61204-3, BS EN/EN61000-6-2 (BS EN/EN50082-2)		
		Parameter	Standard	Test Level/Note
		ESD	BS EN/EN61000-4-2	Level 3, 8 kV air; Level 2, 4 kV contact; Criteria A
		Radiated	BS EN/EN61000-4-3	Level 3, 10 V/m; Criteria A
		EFT/Burst	BS EN/EN61000-4-4	Level 3, 2 kV; Criteria A
		Surge	BS EN/EN61000-4-5	Level 4, 2 kV/Line-Line; Level 4, 4 kV/Line-Line-Chassis; Criteria A
		Conducted	BS EN/EN61000-4-6	Level 3, 10 V; Criteria A
		Magnetic Field	BS EN/EN61000-4-8	Level 4, 30 A/m; Criteria A
OTHERS	MTBF	1723.2k hrs min. Telcordia SR-332 (Bellcore); 324.4k hrs min. MIL-HDBK-217F (25°C)		
	OTHERS DIMENSION	40*125.2*116 mm (W*H*D)		
	PACKING	610 g; 16 pcs/12.2 kg/1.27 CUFT		
NOTE	<ol style="list-style-type: none"> All parameters NOT specially mentioned are measured at 230 VAC input, rated load and 25°C of ambient temperature. Ripple & noise are measured at 20 MHz of bandwidth by using a 12" twisted pair-wire terminated with a 0.1 µF & 47 µF parallel capacitor. Tolerance: includes set up tolerance, line regulation and load regulation. The ambient temperature derating of 3.5°C/1000 m with fanless models and of 5°C/1000 m with fan models for operating altitude higher than 2000 m (6500 ft). Installation clearances: 40 mm on top, 20 mm on the bottom, 5 mm on the left and right side are recommended when loaded permanently with full power. In case the adjacent device is a heat source, 15mm clearance is recommended. The power supply is considered a component which will be installed into a final equipment. The final equipment must be re-confirmed that it still meets EMC directives. 			

Block Diagram

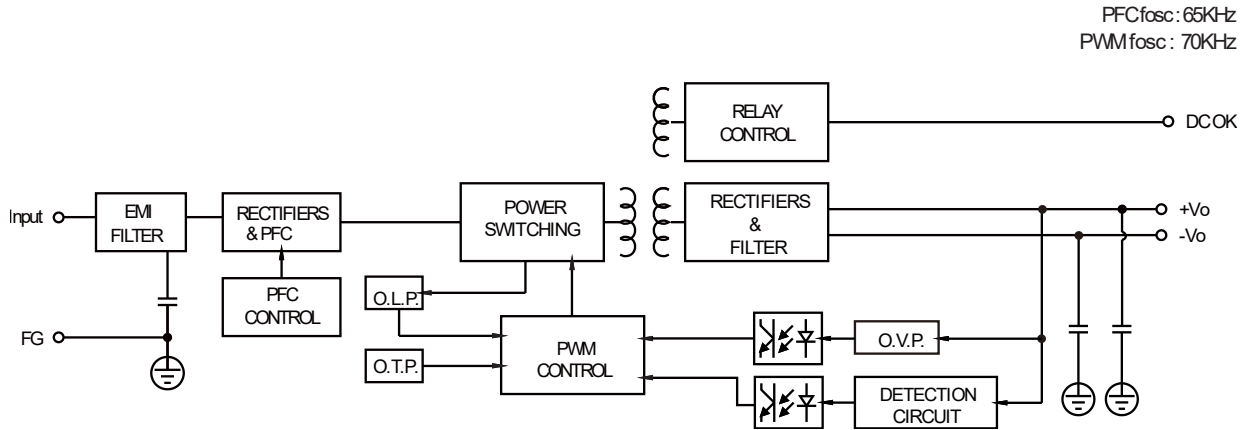

Derating Curve

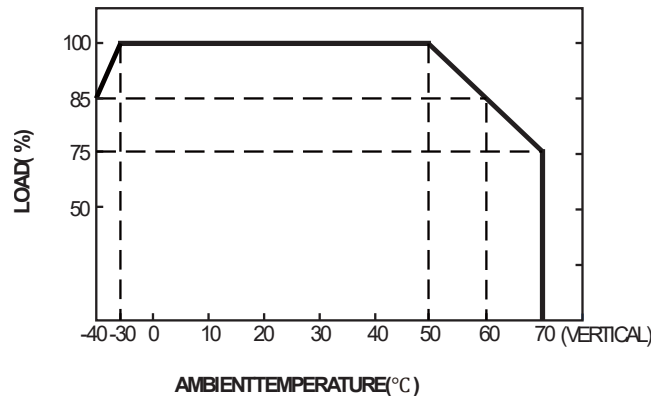

Derating Curve

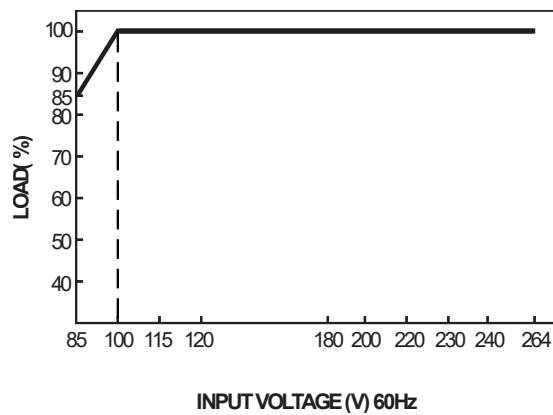

Function Manual – DC OK Relay Contact

Contact Close	PSU turns ON/DC OK
Contact Open	PSU turns OFF/DC Fail
Contact Ratings (Max.)	30 VDC/1 A, 30 VAC/0.5 A resistive load

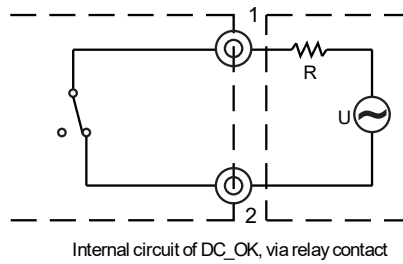

External voltage source (U) and resistor (R)
(The max. Sink is 30Vdc/1A, 30Vac/0.5A)

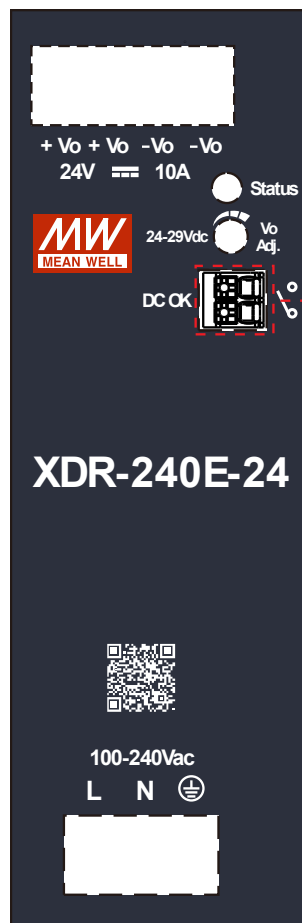

Dimensions and Mechanical Specification

(Unit:mm, Tolerance ± 1mm)

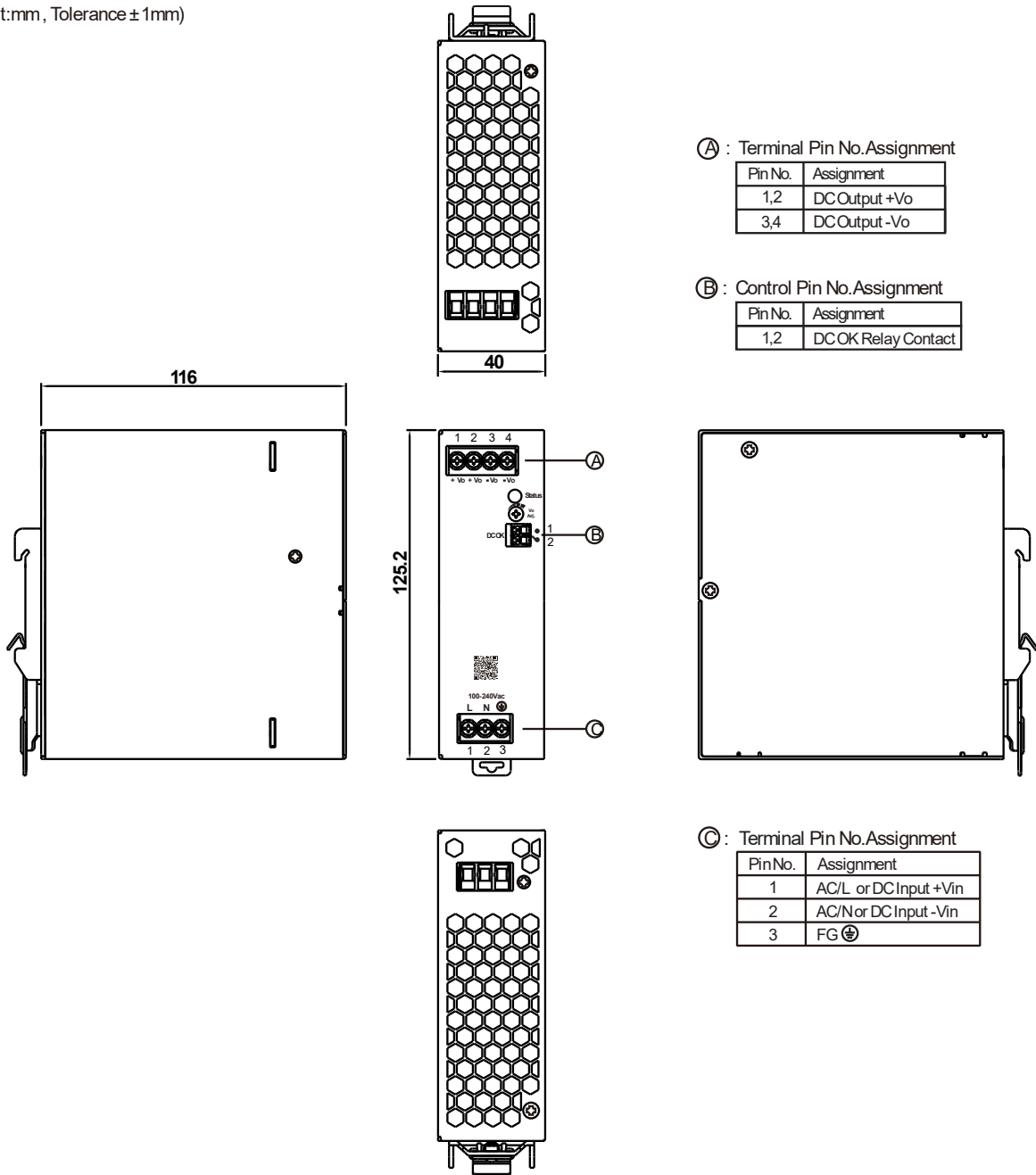

Recommended Wiring

	AC Input Terminal	DC Output Terminal	Signal Connector
Solid Wire	6 mm ² max.	6 mm ² max.	1.5 mm ² max.
AWG	22 ~ 10 AWG	18 ~ 10 AWG	24 ~ 16 AWG
Wire Stripping Length	7 ~ 8 mm	7 ~ 8 mm	8 ~ 9 mm
Screw Terminal Torque	5 lb-in	5 lb-in	/

Installation Instruction

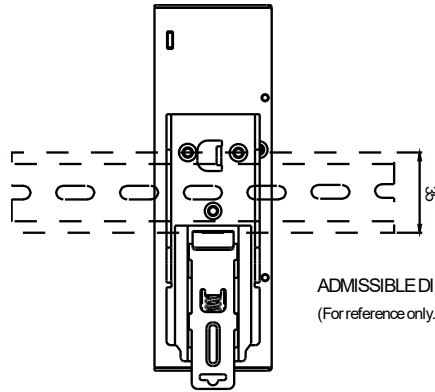

ADMISSIBLE DIN-RAIL: TS35/7.5 OR TS35/15
(For reference only. Not included with unit.)

Product Ordering Information

Standard Package

Part No.: SD.PE-0026-MW

- 240 W AC-to-48VDC Industrial Power Supply
- 85 ~ 264 VAC In, 48 VDC @ 5 A Out, 240 W
- With DIN-Rail Mounting Kit

Contact Us

- Email: sales@altaitechnologies.com or info@altaitechnologies.com

DS-PS240W48V-260131-V1.0

The information contained herein is subject to change without prior notice.